

TECHNICAL ORDER NO. 63-45 ORDERS CONSOLE AND JACK BOX TYPE CONTROLS MODIFIED

Modifications of C-127/ARC, C-126/ARC, C-137/ARC Console Type Controls, C-38/ARC-5 Control Box Type Control Will Result in Better Operation of Aircraft Radio Systems

BuAer Technical Order No. 63-45, dated 12 July 1945, outlines modifications which will improve operations of the radio communications-radio navigation system in VF, VTB and VSB aircraft by presenting a more equalized audio output level to the pilot. Further, these changes will reduce the interaction between the audio output levels of the communication and navigation receivers.

This Technical Order directs that the following modifications be made:

C-127/ARC Master Console Control

1. Disconnect wires which are presently connected to pins "D" and "E" of receptacle AN-3102-20-14P.
2. Connect wire which was formerly on pin "D" to pin "E."
3. Connect wire which was formerly on pin "E" to pin "D."
4. The wiring in this unit should now be in accordance with BuAer drawing E-1270 (Fig. 1).

C-126/ARC Mixer Console Control

1. Procure a 400 to 450-ohm $\frac{1}{2}$ -watt fixed resistor (ASO Stock No. R16-R-17263-53 is suitable) for insertion in the incoming VHF audio line.
2. Disconnect from center pole of VHF audio "OFF-ON" toggle switch the lead which runs from this switch to pin "U" of receptacle AN-3102-22-14P.

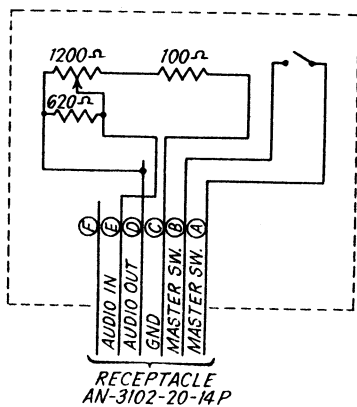

Figure 1—Modification of C-127/ARC Master Console Unit

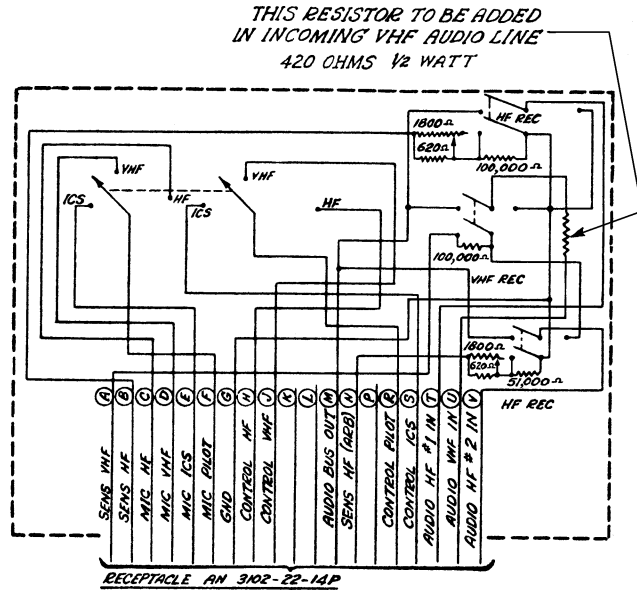

Figure 2—Modification of C-126/ARC Mixing Console Unit

3. Connect one end of the above resistor to this lead.
4. Connect the other end of the resistor to the vacated center pole of the VHF audio "OFF-ON" toggle switch.
5. The wiring in this unit should now be in accordance with BuAer drawing E-1268 (Fig. 2).

C-137/ARC Mixer Console Control

1. Procure a 400 to 450-ohm $\frac{1}{2}$ -watt fixed resistor for insertion in the VHF incoming audio line.
2. Disconnect from center pole of VHF audio "OFF-ON" toggle switch the lead which runs from this switch to pin "U" of receptacle AN-3102-22-14P.
3. Connect one end of the above resistor to the vacated center pole of the VHF audio "OFF-ON" toggle switch.
4. Connect the other end of the resistor to the lead running to pin "U" of receptacle AN-3102-22-14P.
5. The wiring in this unit should now be in accordance with BuAer drawing E-1269 (Fig. 3).

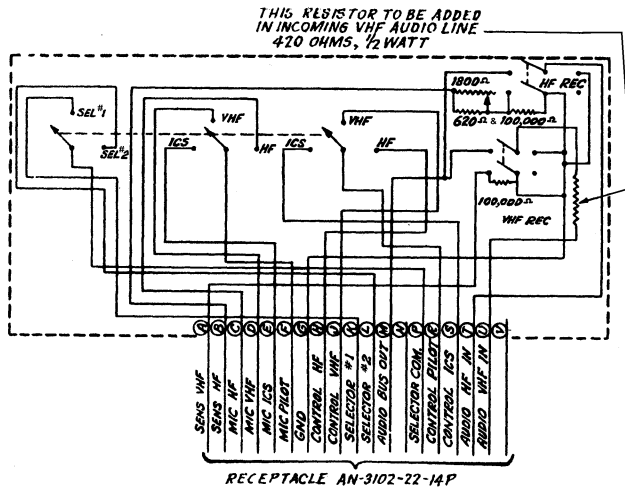
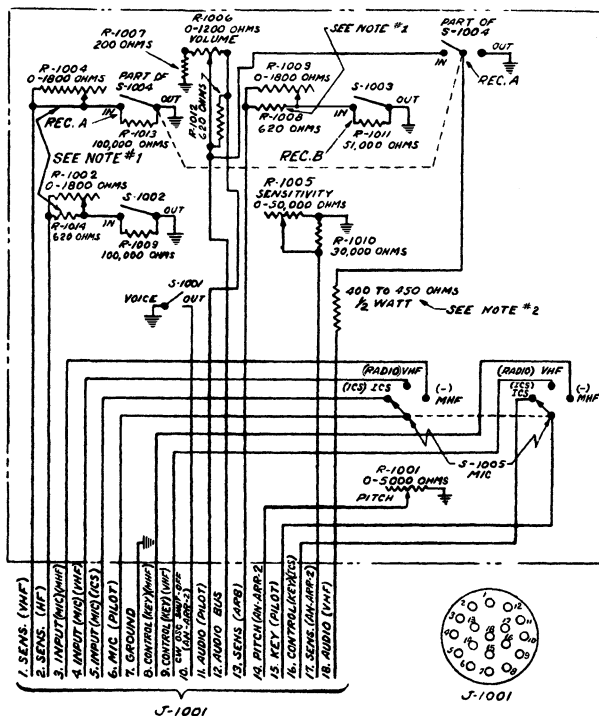

Figure 3—Modification of C-137/ARC Mixing Console Unit

C-38/ARC-5 Control Unit

1. Disconnect lead from rotating arm of potentiometer R-1006.
2. Disconnect both leads from high side of the above potentiometer.
3. Connect lead that was formerly on the rotating arm to the high side of the potentiometer.



NOTES:
 1. STARTING WITH SERIAL #4501 SHORT CIRCUIT ADDED ACROSS R-1004, RESISTOR 1014 ADDED, AND RESISTOR R-1008 CHANGED FROM 2000 TO 620 OHMS ON CBY UNITS ONLY. ALL CCT UNITS HAVE CHANGE SHOWN.
 2. THIS FIXED RESISTOR TO BE ADDED IN INCOMING VHF AUDIO LINE.

Figure 4—Type C-38A/ARC-5 Main Control Unit

4. Connect the two leads that were formerly on the high side to the rotating arm of the potentiometer.
5. Procure a 400 to 450-ohm 1/2-watt fixed resistor for insertion in the VHF incoming audio line.
6. Mount the above fixed resistor in a convenient place in the control unit.
7. Remove the lead running from pin "18" of receptacle J-1001 to the center pole of S-1004.
8. Run new lead from pin "18" of the above receptacle to one side of the fixed resistor.
9. Run new lead from the other side of the fixed resistor to the center pole of switch S-1004 which was vacated by the removal of the old lead.
10. The wiring in this unit should now be in accordance with BuAer drawing E-1253 (Fig. 4).

J-22B/ARC-5 Jack Box Control Unit

1. Disconnect from high side of potentiometer R-1201 the lead which runs to pin "2" of receptacle J-1202.
2. Disconnect lead from rotating arm of the above potentiometer which runs from the potentiometer to phone jack J-1204.
3. Connect lead that was formerly on the high side of the potentiometer to the rotating arm of the potentiometer.
4. Connect the lead that was formerly on the rotating arm of the potentiometer to the high side of the potentiometer.

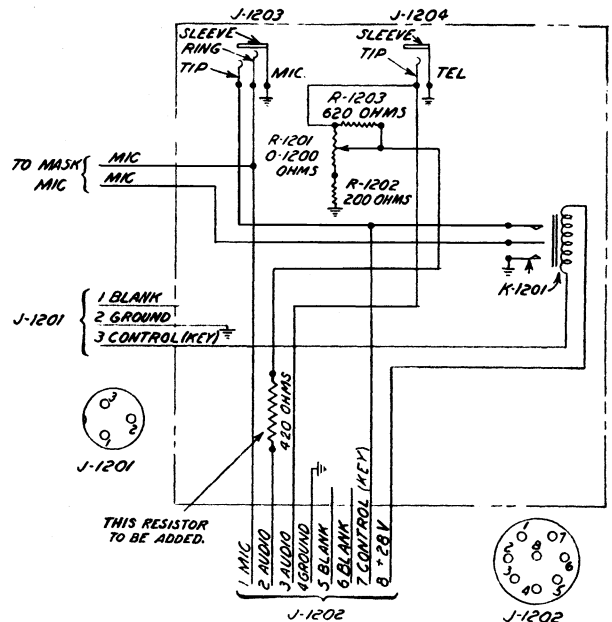

Figure 5—Modification of J-22B/ARC-5 Jack Box

5. Procure a 400 to 450-ohm $\frac{1}{2}$ -watt fixed resistor for insertion in the incoming audio line from pin "2" of receptacle J-1202.

6. Mount the above resistor in a convenient place in the box.

7. Remove the lead from pin "2" of receptacle J-1202.

8. Run new lead from pin "2" of the above receptacle to one side of the resistor.

9. Run lead from the other side of the resistor to the rotating arm of the potentiometer R-1201.

10. The wiring in this unit should now be in accordance with BuAer drawing E-1276 (Fig. 5).

The resistors required for the above modifications are to be obtained from local stock.

Directions contained in this Technical Order do not apply to control units marked: C-127A/-ARC, C-126A/ARC, C-137A/ARC, C-38A/-ARC-5 and J-22C/ARC-5.

Since no more than two of the subject units are installed in any one aircraft, approximately one man-hour per aircraft should be sufficient time to accomplish these changes.

All control units modified in accordance with this Technical Order are to be marked C-127A/-ARC, C-126A/ARC, C-137A/ARC, C-38A/-ARC-5 and J-22C/ARC-5 respectively.

