

31. Switching Relay 1165

a. **FUNCTION OF RELAY.** Relay 1165 is energized when either the TEST KEY, the telegraph key, or the push-to-talk button switch on the microphone is pressed. The functions performed by the six sets of contacts (fig. 19), when the relay is energized, are given below in table III.

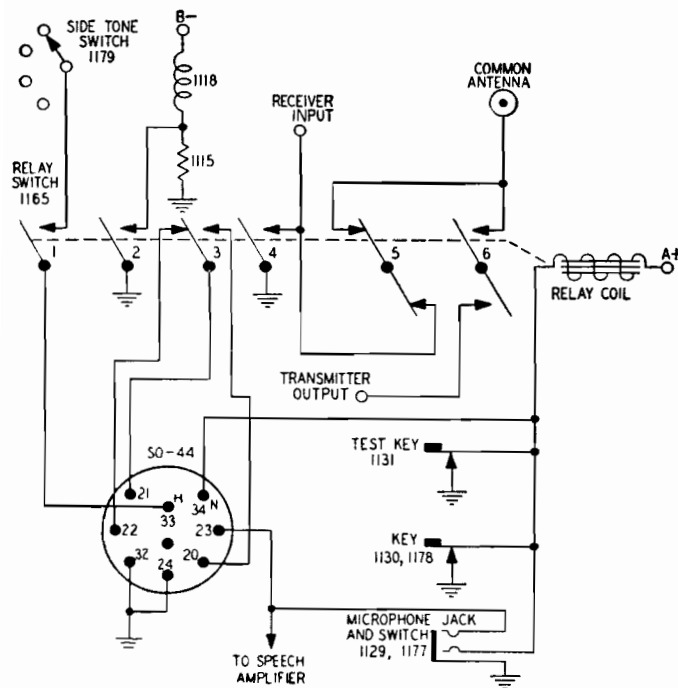

SWITCH SHOWN IN RECEIVE POSITION.
EITHER TEST KEY, KEY, OR MICROPHONE SWITCH THROWS SWITCH TO TRANSMIT POSITION AND SWITCH SECTIONS FUNCTION AS FOLLOWS:

1. CONNECTS SIDE TONES TO RECEIVER.
2. REMOVES BIAS RESISTOR 1115 FROM CIRCUIT.
3. ACTUATES RELAY IN RECEIVER.
4. GROUNDS RECEIVER ANTENNA.
5. DISCONNECTS RECEIVER FROM ANTENNA.
6. CONNECTS TRANSMITTER TO ANTENNA.

TL19521

Figure 19. Switching relay, simplified diagram.

Table III. Relay functions.

Contact No.	Function
1	Connects side-tone line from transmitter to the receiver audio circuit.
2	Shunts out the stand-by biasing voltage developed across resistor 1115.
3	Operates stand-by relay in the receiver.
4	Grounds receiver antenna at transmitter.
5	Disconnects antenna from receiver.
6	Connects antenna to transmitter.

The proper sequence of operation is such that when the transmitter key is closed all other functions of the relay will be performed before the transmitter plate circuits are energized.

When the transmitter key is open, the transmitter plate circuits will be deenergized before any other function of the relay is performed. If making repairs other than necessary contact adjustments, and the relay is found to be defective, remove it and make the repairs. If the damage is such that repairs cannot be made, replace the damaged relay with a good one.

b. **REMOVING RELAY.** When removing any wires connected to the relay, tag all wire leads and mark them so that they can be connected to their original positions. Remove the relay in the following manner:

(1) Remove top and rear panels of transmitter case.

(2) Remove all circuit elements and wires connected to the relay.

(3) Take out the five screws holding the relay in place. These screws are reached from the back of the relay, and are best removed with an offset screw driver.

(4) With a swinging motion, pull the relay, left and first, through the opening between the top of the transmitter frame and the antenna inductor.

c. **CHECKING RELAY AND REPLACING DEFECTIVE PARTS.** (1) Take relay apart and examine it for defective parts such as bent armature, broken leads, cracked insulators, and bent, pitted, or worn contact points.

(2) Check the relay energizing coils for opens or shorts. Use the low-ohm scale of the ohmmeter for this check, since the approximate resistance of the relay coil is only 13 ohms.

(3) Replace any badly pitted or worn points or other defective parts.

(4) Clean all contact points with dry-cleaning solvent (SD) to remove any dirt or grease.

Caution: Do not use such materials as file or emery or crocus cloth for cleaning silver relay contacts as nonconducting materials may become imbedded in the points. On silver-plated contacts such abrasives will remove the plating, causing the contacts to burn or pit easily and to wear quickly.

(5) After cleaning and replacing all defective parts, reassemble the relay and mount it in place on the transmitter.

(6) Replace all wires and circuit elements; be careful that they are put in the positions marked on the tags.

d. **CHECKING RELAY-CONTACT SEQUENCE AND**

TOTAL PL. CURRENT METER ACCURACY. A simple type of tester that is very helpful in checking contact sequence of the relay and accuracy of the TOTAL PL. CURRENT meter on Radio Transmitter BC-191-(*) is shown in figure 20. The pressure-arm attachment (fig. 20), when clamped to the relay (fig. 21), is used for operating the relay manually. By slowly pushing the pressure arm downward, the contacts of the relay can be closed one at a time. This slow action is necessary in order to check the closing of each individual contact by observing the test lights on the tester. The pressure-arm adjustment attachment (fig. 20) is mounted on the top panel of the transmitter and is used to operate the pressure arm so that a fixed pressure may be maintained, if necessary, when any adjustments have to be made on the relay contacts. The use of this attachment makes it possible to have both hands free for the adjustments. (See fig. 22.) If it is necessary to make adjustments on a number of relays, the pressure-arm adjustment attachment can be permanently mounted on a spare transmitter top panel. This can be used as a piece of the test equipment and will save considerable time in mounting and unmounting the adjustment plate. Along with this dummy top panel, a dummy antenna terminal board (fig. 20) can be made to use with the test equipment. Figure 25 gives the dimensions of the suggested pressure arm and pressure-arm adjustment attachments; the schematic diagram of the suggested sequence tester is shown in figure 26. The long-nose pliers (fig. 23) are made by drilling the tops and inserting small points to fit the holes in the relay-contact locknuts; the angle tool for making the contact adjustments is a piece of piano wire. Any arrangement that will satisfactorily do the work may be used for these adjustments. To connect and operate the tester, proceed as follows:

(1) Remove all plugs and cables from transmitter.

(2) Remove top and rear panels from transmitter.

(3) Connect Plugs PL-64 and PL-61 on tester to corresponding sockets on the transmitter. High voltage is not used with the tester.

(4) Connect a jumper between LOAD B and GND. terminals on transmitter-output terminal board.

(5) Connect a jumper between the common arm of SIDE TONE switch and chassis.

(6) Connect leads from ANT. and REC. terminals on transmitter-output terminal board to respective posts on tester.

(7) Clamp pressure-arm attachment on relay. (See fig. 21.)

(8) Connect sequence tester to 110-volt a-c. and turn the OFF-ON switch on the tester to ON; this should light the panel pilot lamp.

(9) Operate pressure-arm attachment slowly, and at the same time observe test lights 1 to 7, inclusive, for proper sequence operation. Use push button on tester to operate test light 7.

(10) If the test lights do not operate in order, if they flicker and are erratic, slowly screw down the pressure-arm adjustment attachment until the contacts causing the erratic operation are closed. (See fig. 24.) With the special long-nose pliers, or any substitute tool unlock the contact locknut and adjust the contact point until the light on the tester operates properly.

(11) When test light 6 is lit, both the TOTAL PL. CURRENT meter on the transmitter and the meter on the tester should indicate the same value of current, ± 2 percent. Test light 6 does not burn as brightly as the other lights because of the 10-ohm shunt resistor.

(12) After making the relay adjustments, remove the pressure arm and pressure-arm adjustment attachment and replace transmitter panels.

Caution: After completing the adjustments, do not forget to remove the jumper from the SIDE TONE switch to ground before replacing panels.

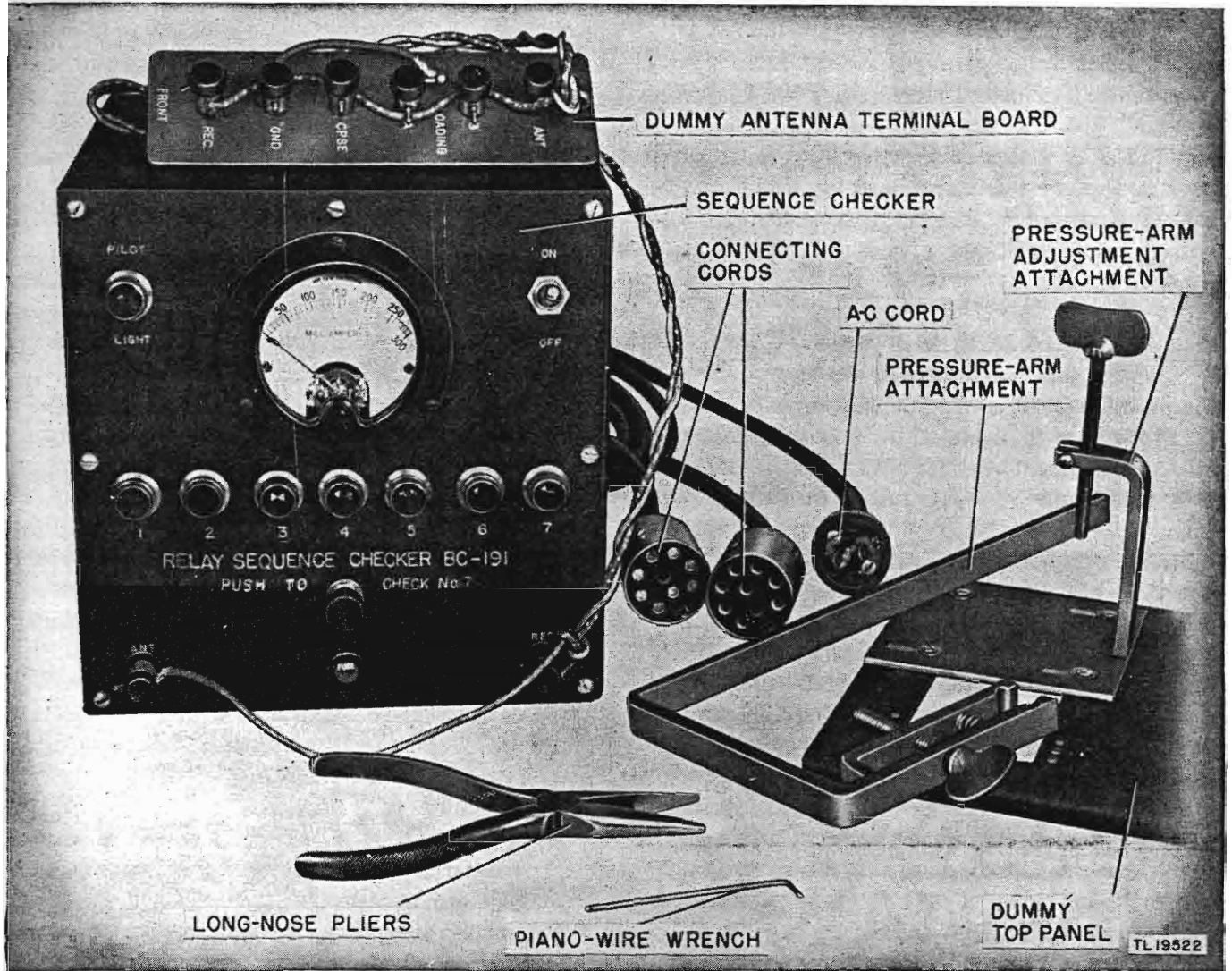

Figure 20. Relay-checking equipment.

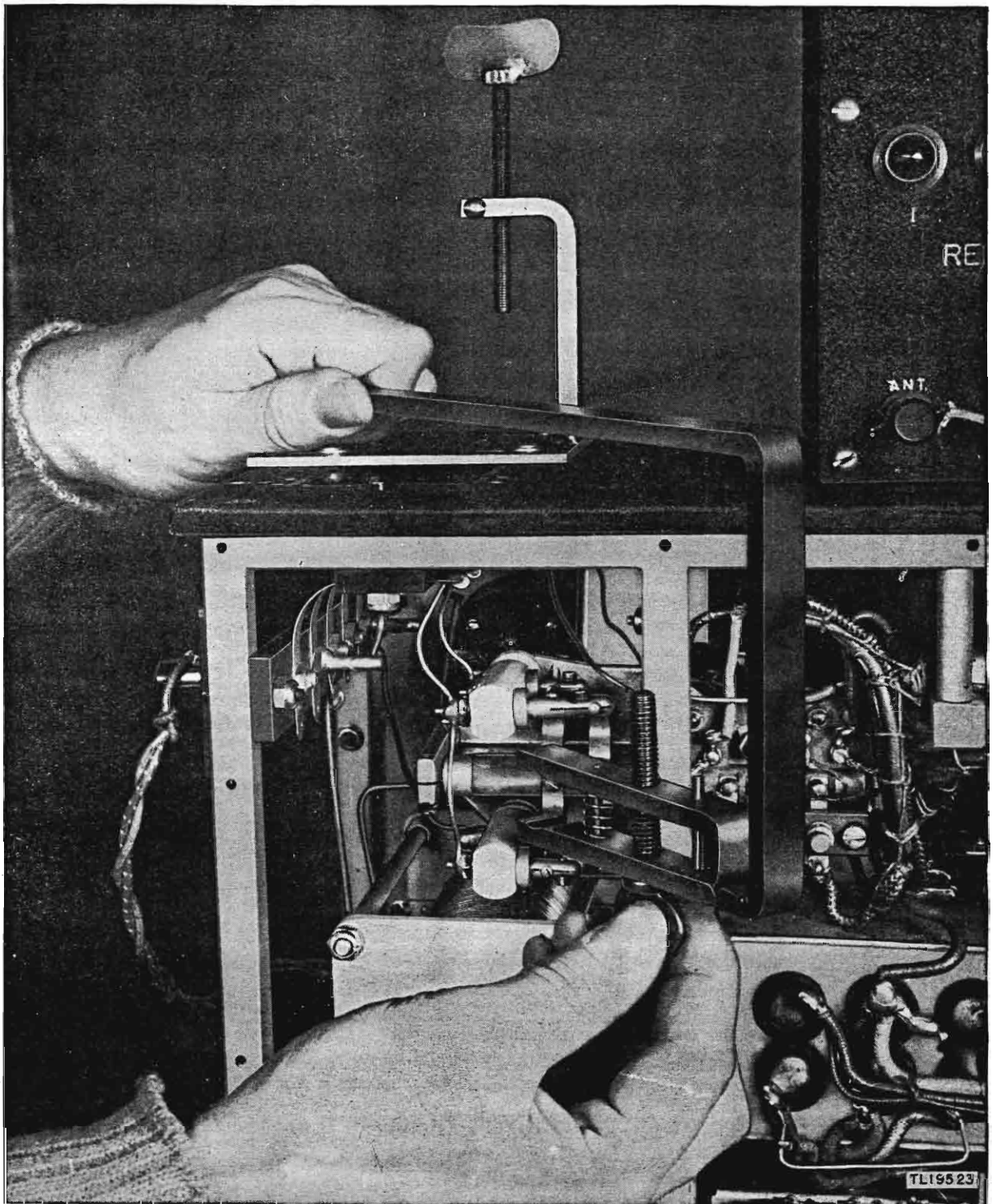

Figure 21. Clamping pressure-arm attachment to relay.

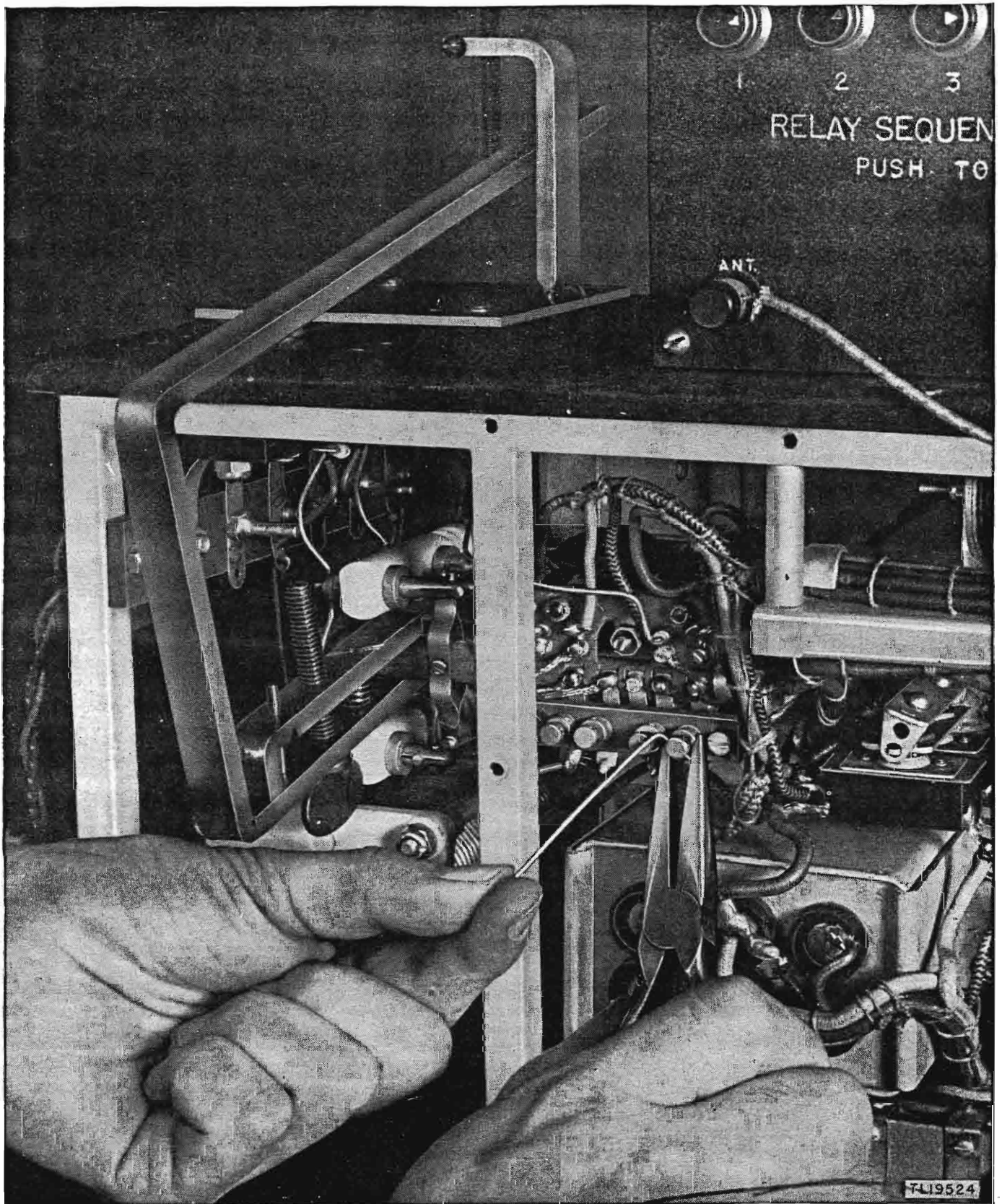

Figure 22. Pressure-arm adjustment attachment in use.

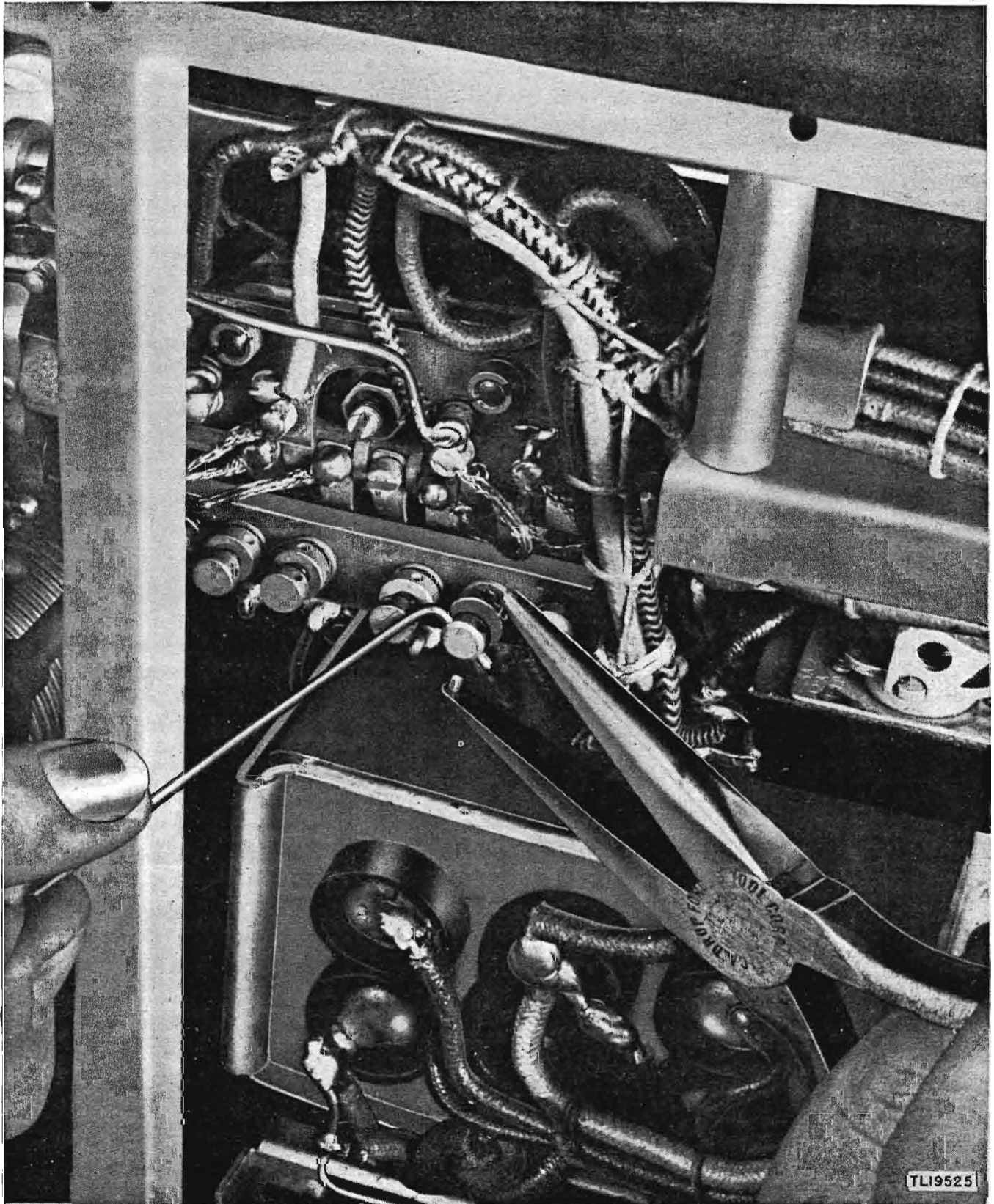

Figure 23. Close-up view of long-nose pliers.

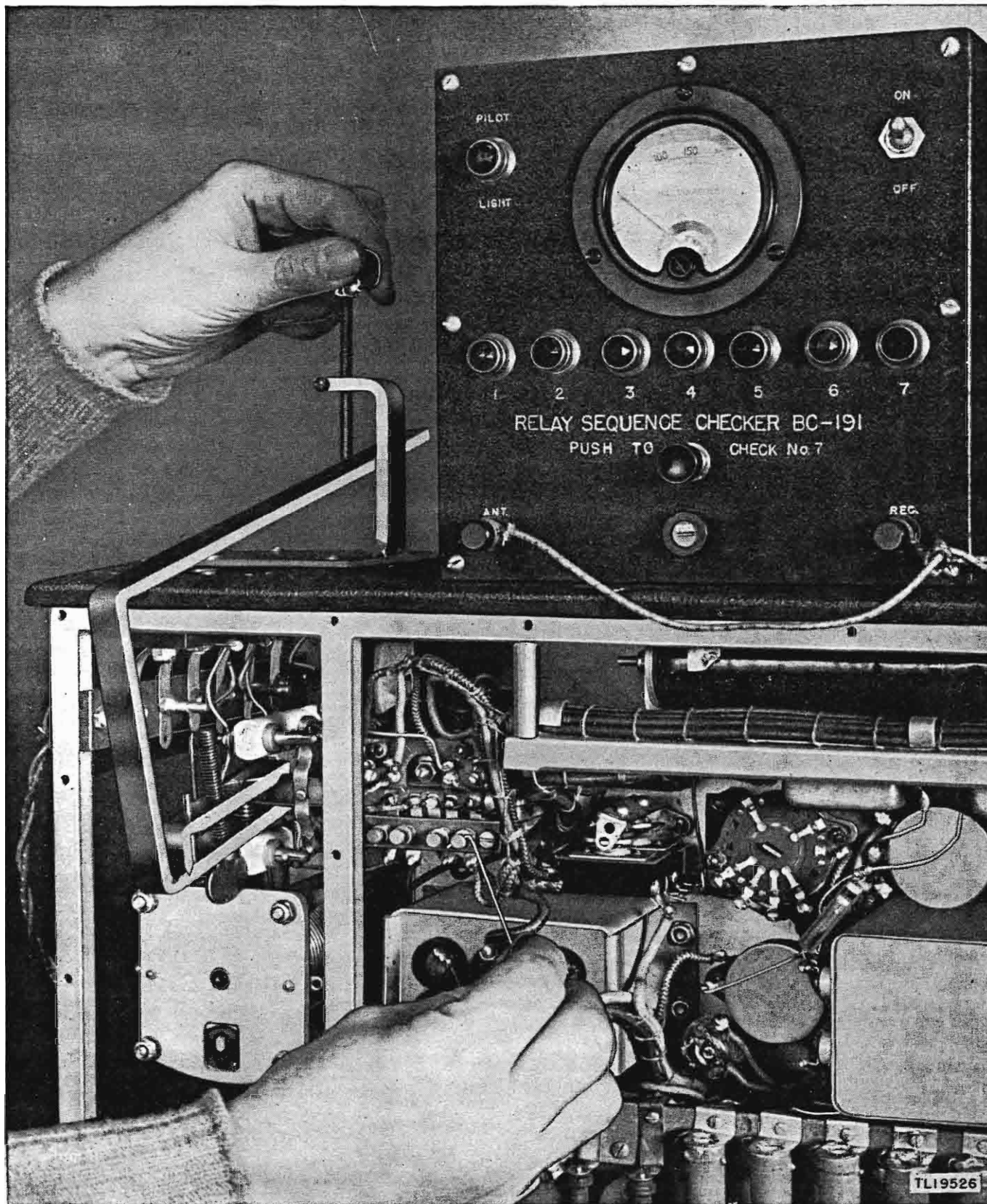

Figure 24. Operating pressure-arm adjustment attachment.

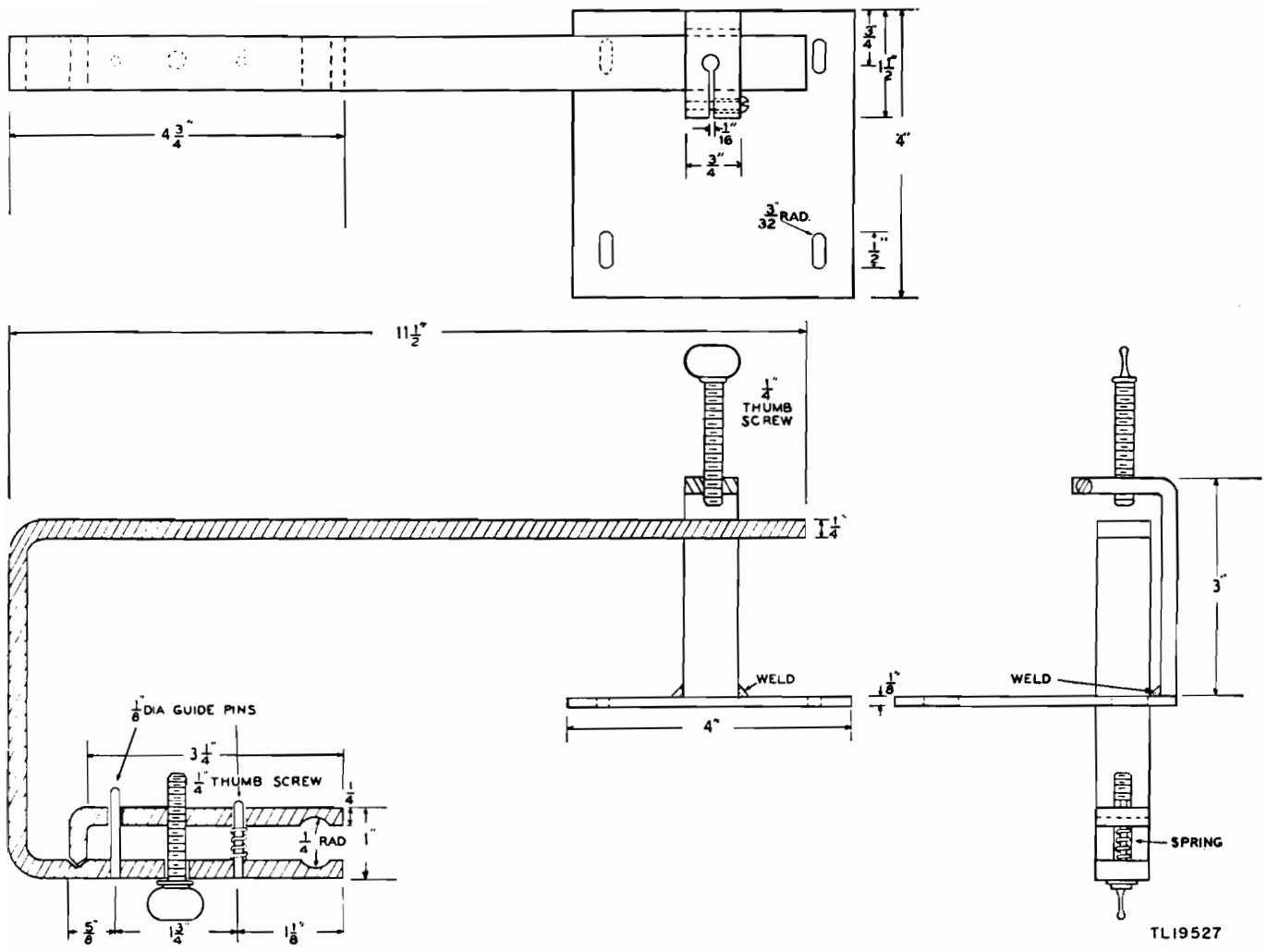
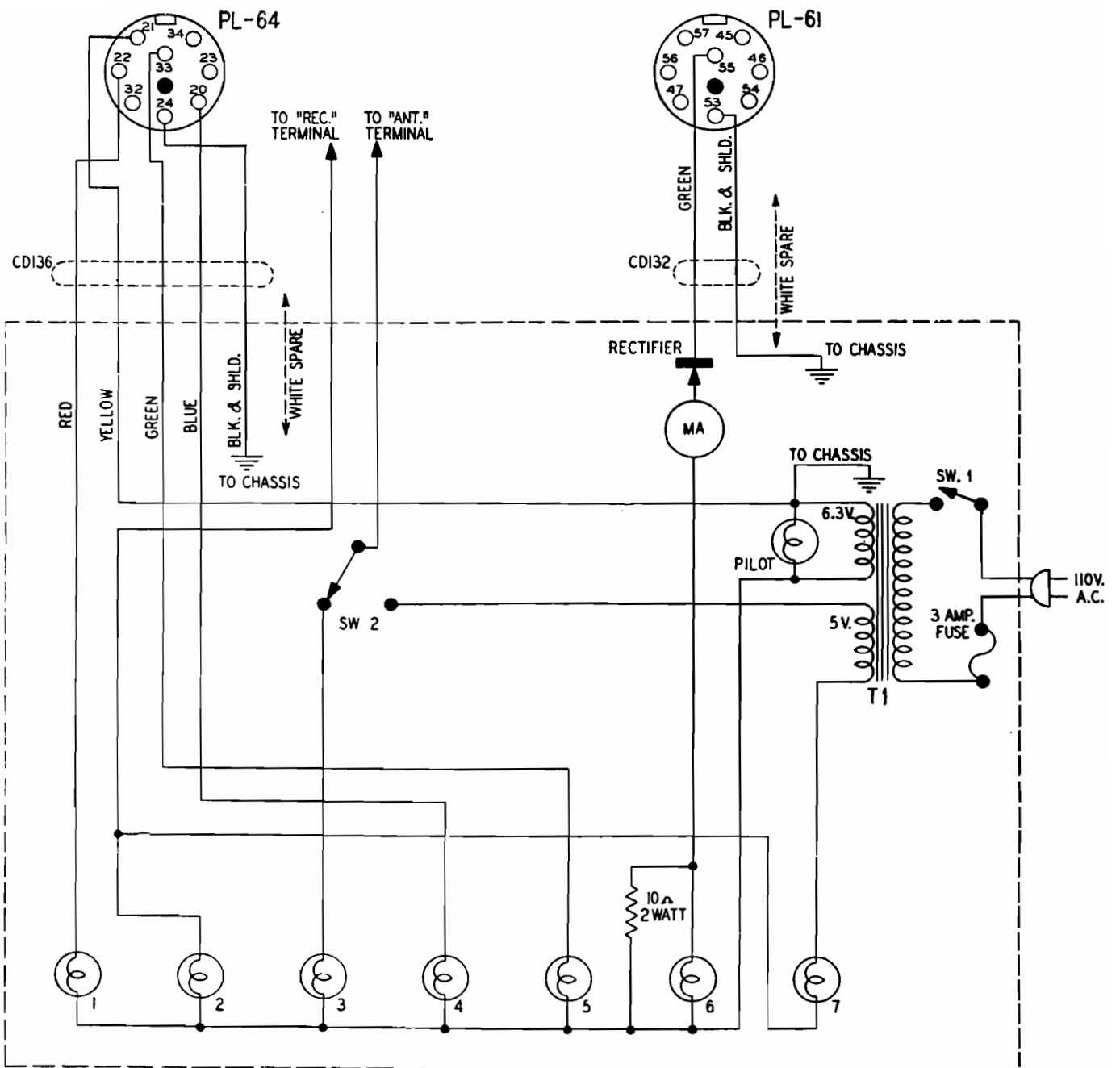

Figure 25. Constructional data for pressure arm and pressure-arm adjustment attachment.

e. PARTS DATA (fig. 26).

Signal Corps stock No.	Name of part and description	Function
3F930 or 3F950	AMMETER: 0-500 milliamperes d-c. AMMETER: 0-300 milliamperes d-c (either type meter can be used).	Check accuracy of TOTAL PL. CURRENT meter on transmitter.
CD-136	CABLE: 6 wires; one not used.	Connects tester to transmitter.
CD-132	CABLE: 3 wires; one not used.	Connects tester to transmitter.
3Z3275 2Z5991-4	FUSE HOLDER: panel type; 3-amp fuse. MOUNTING ASSEMBLY: for pilot and indicator lights.	Protects tester. Holds indicator and pilot lights.
2Z5927	PILOT LAMPS: 6.3-v; 0.25-amp; (S44).	Pilot light and contact indicators.
2Z7164.3	PLUG: male; a-c type. PLUG PL-64: (used on cord CD-136).	Power cord plug for tester. Connects cord CD-136 to transmitter.
2Z7161.3	PLUG PL-61: (used on cord CD-132).	Connects cord CD-132 to transmitter.
3H4855	RECTIFIER: copper oxide or selenium; 2C679A for Remote Control Unit RM-13-A; 8 plates used in half-wave.	Rectifies ac to operate tester meter.
3RC41AE 3Z9824-259	RESISTOR: wire-wound 10-ohm 2-w. SWITCH: SPDT; push-button type; momentary contact (SW. 2).	Stabilizing resistor. Operates test light 7.
3Z8105	SWITCH: single-pole; toggle type (SW. 1).	OFF-ON switch.
	TERMINAL POSTS: (to REC) and (to ANT).	Connect tester to respective terminals on transmitter.
	TRANSFORMER: any small power transformer or filament transformer with 6.3-v and 5-v windings.	Supplies power for test lights and meter.



TL19528

Figure 26. Relay sequence tester, schematic diagram.

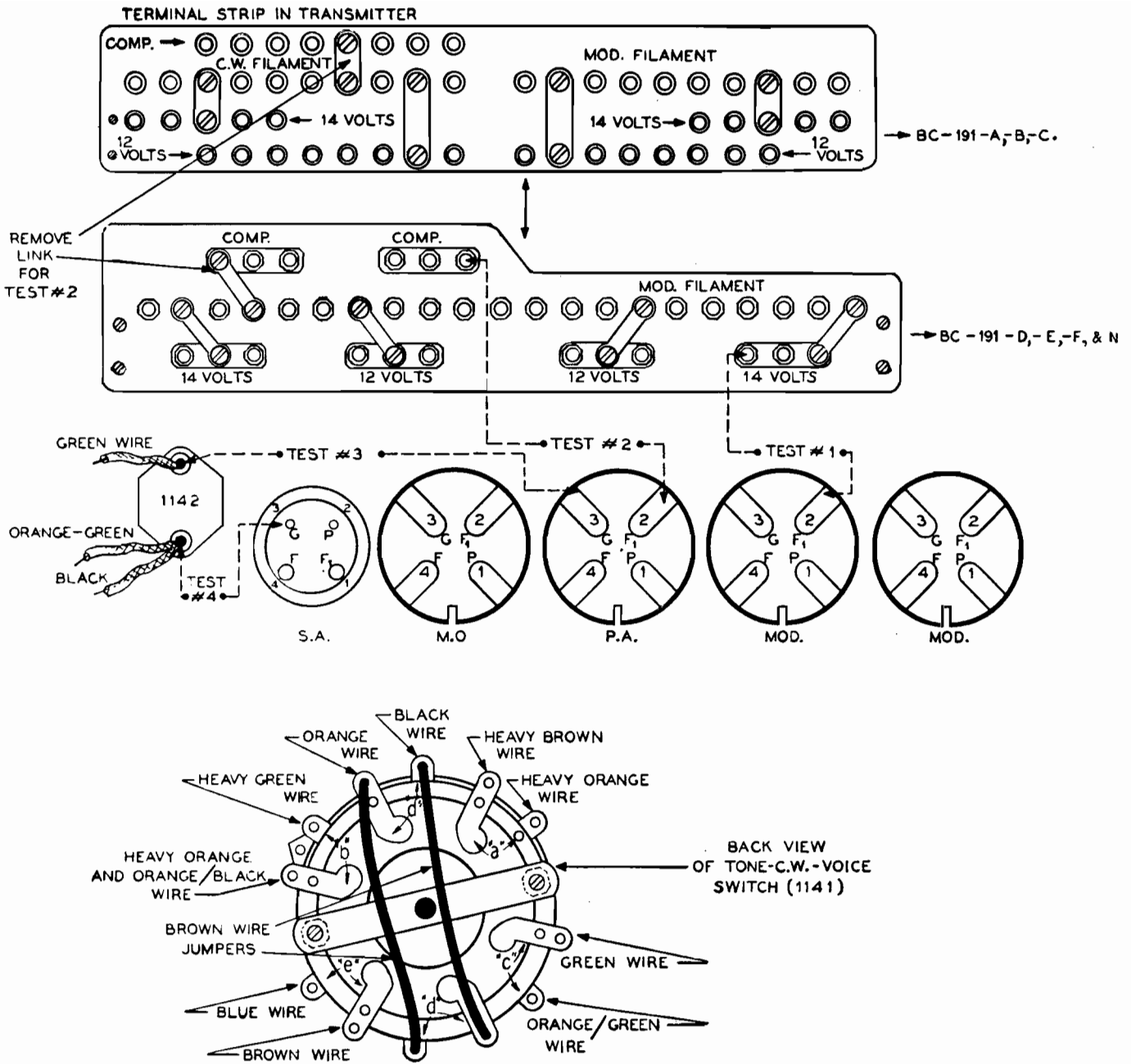

NOTE: SEE FIGURE 36 FOR LOCATION OF CAPACITOR 1142, AND FIGURE 34 FOR INPUT TRANSFORMER 1149.

TL19529

Figure 27. Test points for checking TONE-C.W.-VOICE switch.